

SPÉCIFICATIONS:

Dimension	Description	Type 1	Type 2
D1	Internal diameter	571.5 ± 2	571.5 ± 2
D2	External Diameter	585, Max	596, Max
D3	Diameter over chimb	585, Max	587, Max
D4	Diameter over closing ring	585 Max 1)	610 Max
H1	Total Drum height	878 ± 5	878 ± 5
H5	Height with cover off	868 ± 5	868 ± 5
h2	Depth of top	Note	Note
h3	Clearance from floor	4, Min	4, Min
h4	Distance between beads	280 ± 3	280 ± 3
p1	Center-to-center distance closures	451 ± 1	451 ± 1

1) The diameter over closing ring shall normally be a maximum 585 mm but may be slightly larger, if measured over the lever section or bolt section of the ring

Note The depth of the top shall be such that the clousures do not protude above the chime



200 /210 Liter nominal capacity barrel made from 1.25mm (18G) x 1.25mm (18G) nominal thickness mild steel CRCA sheets.

Body Seam: Electrically resistance welded.

Bottom Seam: Triple seamed incorporating imported seaming compound.

Top End: Fitted with one 50 mm (2") & one 20 mm (3/4") closures. Completely removable & with GI Lever type locking Ring.

Body: Provided with 2 expanded rolling hoops.

External Finish: One coat of stoving enamel paint on the outside.

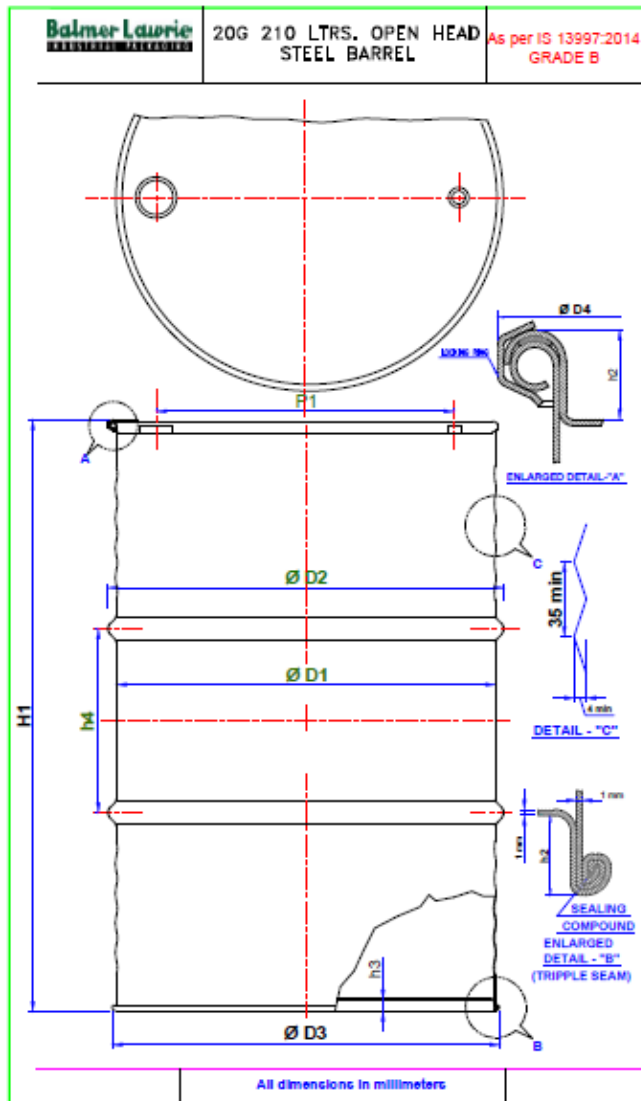

SPÉCIFICATIONS:

Dimension	Description	Type 1	Type 2
D1	Internal diameter	571.5 ± 2	571.5 ± 2
D2	External Diameter	585, Max	596, Max
D3	Diameter over chimb	585, Max	587, Max
D4	Diameter over closing ring	585 Max 1)	610 Max
H1	Total Drum height	878 ± 5	878 ± 5
H5	Height with cover off	868 ± 5	868 ± 5
h2	Depth of top	Note	Note
h3	Clearance from floor	4, Min	4, Min
h4	Distance between beads	280 ± 3	280 ± 3
p1	Center-to-center distance closures	451 ± 1	451 ± 1

1) The diameter over closing ring shall normally be a maximum 585 mm but may be slightly larger, if measured over the lever section or bolt section of the ring

Note The depth of the top shall be such that the clousures do not protude above the chime



200 /210 Liter nominal capacity barrel made from 1.00mm (20G) x 1.00mm (20G) nominal thickness mild steel CRCA sheets.

Body Seam: Electrically resistance welded.

Bottom Seam: Triple seamed incorporating imported seaming compound.

Top End: Fitted with one 50 mm (2") & one 20 mm (3/4") closures. Completely removable & with GI Lever type locking Ring.

Body: Provided with 2 expanded rolling hoops and corrugation.

External Finish: One coat of stoving enamel paint on the outside.

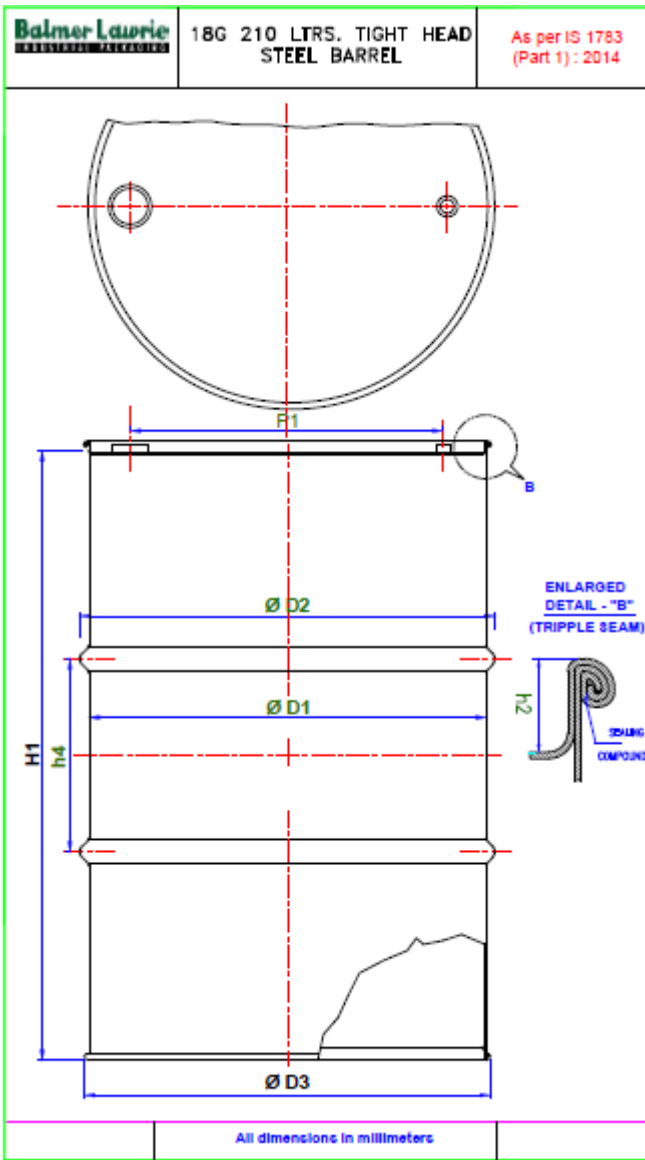

SPÉCIFICATIONS:

Dimension	Description	Type 2C	Type 2D
D1	Internal diameter	571.5 ± 2	571.5 ± 2
D2	External Diameter	585, Max	596, Max
D3	Diameter over chimb	585, Max	585, Max
H1	Total Drum height	878 ± 5	878 ± 5
h2	Depth of top	1)	1)
h3	Clearance from floor	4, Min	4, Min
h4	Distance between beads	280 ± 3	280 ± 3
p1	Center-to-center distance closures	451 ± 1	451 ± 1

1) The depth of the top shall be such that the clousures do not protude above the chime



200 /210 Liter nominal capacity barrel made from 1.25mm (18G) x 1.25mm (18G) nominal thickness mild steel CRCA sheets.

Body Seam: Electrically resistance welded.

Ends Seam: Triple seamed incorporating imported seaming compound.

Top End: Fitted with one 50 mm (2") & one 20 mm (3/4") closures.

Body: Provided with 2 expanded rolling hoops.

External Finish: One coat of stoving enamel paint on the outside.

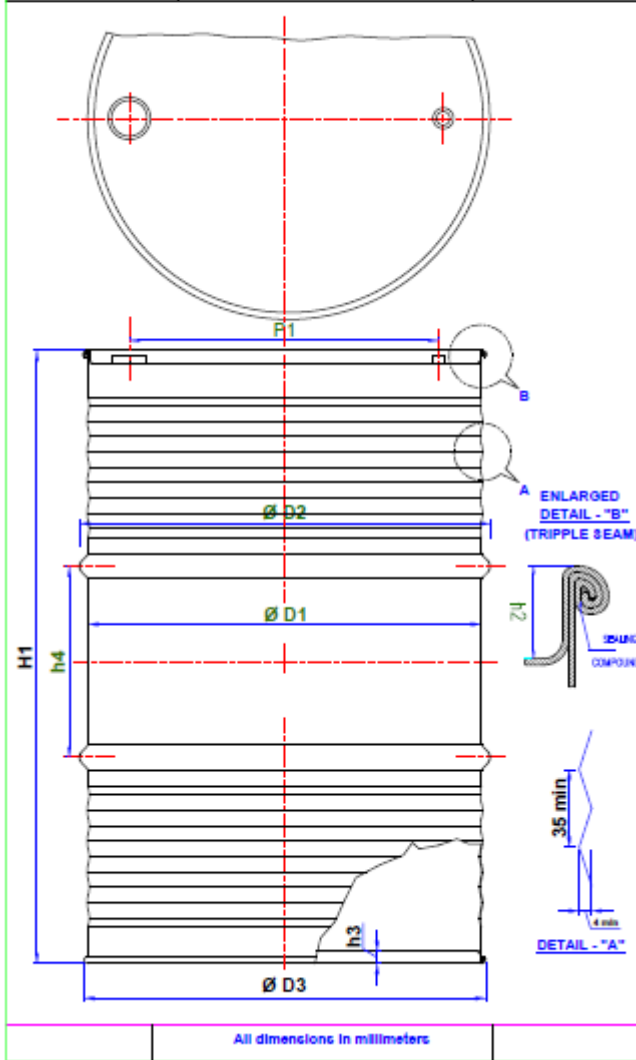

SPÉCIFICATIONS:

Dimension	Description	Type 2C	Type 2D
D1	Internal diameter	571.5 ± 2	571.5 ± 2
D2	External Diameter	585, Max	596, Max
D3	Diameter over chime	585, Max	585, Max
H1	Total Drum height	878 ± 5	878 ± 5
h2	Depth of top	1)	1)
h3	Clearance from floor	4, Min	4, Min
h4	Distance between beads	280 ± 3	280 ± 3
p1	Center-to-center distance closures	451 ± 1	451 ± 1

1) The depth of the top shall be such that the closures do not protrude above the chime



200 / 210 Liter nominal capacity barrel made from 1.00mm (20G) x 1.00mm (20G) nominal thickness mild steel CRCA sheets.

Body Seam: Electrically resistance welded.

Ends Seam: Triple seamed incorporating imported seaming compound.

Top End: Fitted with one 50 mm (2") & one 20 mm (3/4") closures.

Body: Provided with 2 expanded rolling hoops and corrugation.

External Finish: One coat of stoving enamel paint on the outside.